

Experience a safer
and more open world



Strengthen your building's access control with an elegant and compact swing speedgate, specially created for monitoring and deterring unauthorised traffic.

The speedgate turnstile SG100 from ASSA ABLOY is a dependable and stylish solution for regulating the people flow in and out of your building. SG100 is a highly effective entryway that can monitor and block unwanted access as / if necessary, significantly contributing towards a steady level of safety and security in your environment.

The gate's galvanized coated steel frame and stainless steel housing panels, together with its 10 mm tempered glass top lid and illuminated indication pictograms, make it a sleek, high-quality addition to your building's entryway. What makes it stand out from our other solutions, however, is its intuitive Access Control Integration. Our SG100 framework is easily integrated with any access control system through dry contact or COM ports.

You can even choose to customize the gate's top lid, with optional cuts available for surface mount readers, reader holders or stands, as well as standard or custom-designed posts for access controller integration. Just let us know what you need.

Design specification

Construction	Steel
Passage width	650 / 915 / 1000 mm
Weight	115 kg
Power supply	100 to 240 VAC, 50 / 60 Hz
Logic voltage	24 VDC
Operation temperature	0 °C / +50 °C
IP protection	Cabinet IP44
Mean cycles before failures (MCBF)	10 000 000
Mean time to repair (MTTR)	< 30 min.
Opening and closing times	0.8 to 2.6 sec

Options and accessories

- Glass or acrylic barrier wings
- Company logo on glass/acrylic barrier wings
- Powder coated housing panels in RAL color
- Stainless steel base plate
- Card inserter
- Access controller integration brackets (on demand)
- Push button controller
- Touch panel controller

Customizable settings

The SG100 speedgate turnstile has a logic controlled interface and operates bi-directionally. Entrance and exit directions can be individually set as controlled, locked, or free rotation. After the release, the turnstile blocks itself after an adjusted time if no transition or passage occurs. If people from both directions would like to pass through simultaneously, the first person who activates the turnstile comes first.

Controlled access

When in controlled access mode, after the release confirmation sent by the access control system, the gate opens the barrier wings and enables one-person access. After each person, the barrier wings block passage again, and does not permit access from entrance or exit directions until receiving a new release signal from the access control system.

Multiple openings

An additional person is able to use the next passage cycle during an ongoing passage cycle in both directions. The turnstile controller stores up to 255 releases, and can allow the same amount of individuals to pass through.

Security responses

During a security threat or other related incidents, the gate can respond in multiple different ways:

- Acoustic alarm only, without blocking the lane.
- Wings closing immediately and blocking the lane*, without an acoustic alarm.
- Wings closing immediately and blocking the lane*, as well as an acoustic alarm.

* If the lane is blocked during a tailgating attempt or if someone is going the wrong way, the gate's wings can potentially injure the person in question.

Emergency and power outage modes

In the event of an emergency or power outage the gate opens the barrier wings automatically (fail-safe mode). Once the emergency alarm stops and/or the electricity returns, the gate resets itself automatically. Upon request, the system can be configured for manual operation instead of automatic opening.

LED indicators

The LED lights on the turnstile indicate the operating status in both directions.

Blue	Waiting / Standby
Green	Passage confirmed
Red	No passage

Settings

Operation mode for each directions	Controlled / Free / Locked
Acoustic notifications	On / Off
Release time out	5, 10, 15, 20 sec
Emergency connection	On / Off

SG 100 Standart

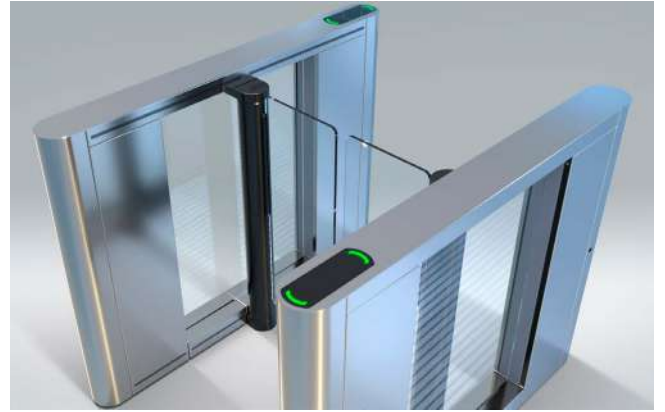
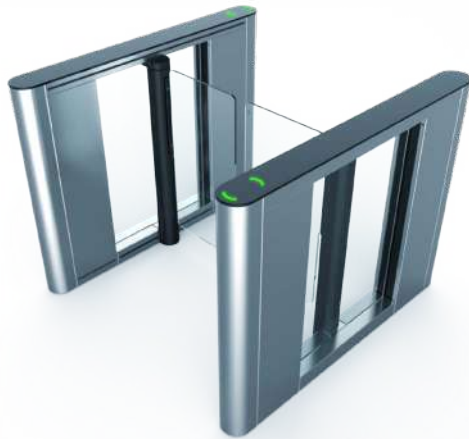

The SG 100 model with stainless steel top lid and body. Integrated with card reader brackets. 950 mm wing height and 650 mm clear passage width.

SG100 WIDE



SG100 BOLD



SG100 FLAT FRONT



The SG 100 model family offers distinctive design variations: Standard, Wide, Bold, and Flat Front. Each carefully crafted to meet different architectural and functional requirements.



SG 100 can be equipped with a 10 mm glass top lid or a stainless steel top lid with integrated LED-indicators.



SG 100

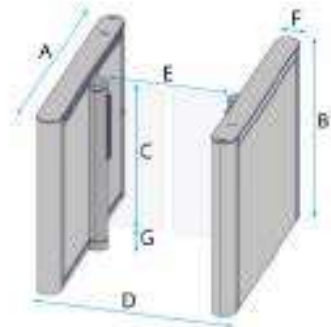

SG 100 Bold

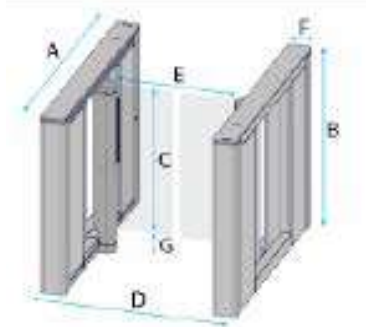

SG 100 Flat Front

SG100 – SG 100 Bold – SG 100 Flat Front

Total Length (A)	1319 mm / 51.93 inch		
Cabinet Height (B)	1020 mm / 40.16 inch		
Barrier Wing Height	960 mm / 37.80 inch	1200 mm / 47.24 inch	1800 mm / 70.87 inch
Wing Height Variants (C)	825 mm / 32.48 inch	1065 mm / 41.93 inch	1665 mm / 65.55 inch
Spacing Between Wings and Finished Floor Level (G)	135 mm / 5.31 inch		
Total Width (D)	1075 mm / 42.32 inch	1340 mm / 52.76 inch	1425 mm / 56.10 inch
Clear Passage Width (E)	650 mm / 25.59 inch	915 mm / 36.02 inch	1000 mm / 39.37 inch
Cabinet Width (F)	132 mm / 5.20 inch		
Spacing Between Wings	50 mm / 1.97 inch		
Weight Left / Right cabinet	SG 100 and SG 100 Flat Front: 115 kg / 253.53 lbs		SG Bold: 110 kg / 242.5 lbs
Weight center cabinet	SG 100 and SG 100 Flat Front: 155 kg / 341.71 lbs		SG Bold: 150 kg / 330.69 lbs

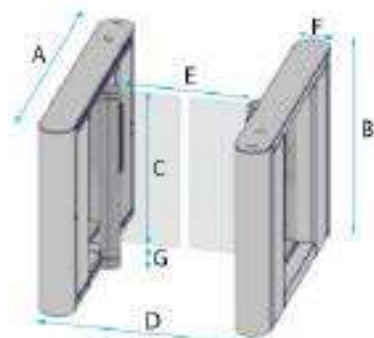

SG 100 Wide

SG100 Wide

Total Length (A)	1319 mm / 51.93 inch
Cabinet Height (B)	1020 mm / 40.16 inch
Barrier Wing Height	960 mm / 1200 mm / 1800 mm 37.80 inch / 47.24 inch / 70.87 inch
Wing Height Variants (C)	825 mm / 1065 mm / 1665 mm 32.48 inch / 41.93 inch / 65.55 inch
Spacing Between Wings and Finished Floor Level (G)	135 mm / 5.31 inch
Total Width (D)	1171 mm / 1436 mm / 1721 mm / 46.1 inch / 56.53 inch / 67.75 inch
Clear Passage Width (E)	650 mm / 915 mm / 1000 mm / 25.59 inch / 36.02 inch / 39.37 inch
Cabinet Width (F)	180 mm / 7.08 inch
Spacing Between Wings	50 mm / 1.97 inch
Weight Left / Right cabinet	125 kg / 275.57 lbs
Weight center cabinet	165 kg / 363.76 lbs

This equipment should be installed, regularly inspected, maintained and serviced by trained and authorized personnel. Preventive maintenance plans are highly recommended for a proper and safe operation. Talk to your ASSA ABLOY Entrance Systems representative to learn more about our service offering!