

Speedgate

ASSA ABLOY SG400

Security entrance control



Strengthen your building's access control with a secure, yet elegant slim speedgate.

The slim speedgate SG400 combines elegant architectural design with advanced security. The SG400 features a slim cabinet with a continuously crafted top panel for seamless experience. Made of premium selection of anodized colours or in complete stainless-steel appearance. To further position the speedgate as part of interior design, a selection of premium colours for powder-coating has been selected.

SG400 delivers high throughput and reliable security performance. Integrated LED indicators clearly signal permitted or denied passage and help guide people naturally through the entrance in both directions. Seamless integration with access control systems, it ensures secure, smooth,

and intelligent pedestrian flow for modern buildings.

The gate can also be customized with optional top lid cut-outs for flush and surface mounted readers, reader holders, stands, or standard and custom-designed posts to suit your access control requirements.

The SG400 features fast-opening, barrier wings manufactured from 10 mm tempered glass as standard. This high-performance system ensures smooth, fast passage while effectively detecting and preventing unauthorized access – maintaining a consistent and reliable level of safety and security in any environment.

Design specification

Construction	Steel
Passage width	650 / 915 / 1000 / 1200 mm
Weight	90 to 195 kg
Power supply	100 to 240 VAC, 50 / 60 Hz
Logic voltage	24 VDC
Operation temperature	0 °C to +55 °C
IP protection	Cabinet IP44
Mean cycles before failures (MCBF)	10 000 000
Mean time to repair (MTTR)	< 30 min.
Opening and closing times	0.7 to 2.7 sec

Options and accessories

- rylic/ Polycarbonate/Lexan or laminated safety glass barrier wings
- Powder coated steel panels
- Stainless steel base plate
- Card inserter
- Access controller integration brackets and posts
- Fail-locked / Emergency-lock
- Climb over sensor

Experience a safer and more open world

High flow rate

The SG400 slim speedgate provides maximum security even for an exceptionally high flow rate of people. The illuminated indication pictograms give clear directions to staff and visitors for the best possible route they can take, and the adjustable gate direction control adds flexibility to all building entrance control systems.

Reliability and long life cycle

Our reliable mechanical system allows for maximum stability, as well as ensuring a consistently low level of maintenance to provide permanent service life – leading to a significantly higher return-on-investment than our competitors' products.

Advanced Security

With our advanced detection system, sensors and sensor-based algorithms work together to track the passage of authorised users, while controlling unauthorised and/or fraudulent attempts at the same time. This provides the maximum security level against unauthorised passages such as tailgating, wrong-way passage etc. (This is also the reason we provide higher barrier wing options – for more details, see Design Specifications.)

Such attempts will be blocked by the fast-closing barrier wings response, while the intrusion alarm warning will be activated during endeavours such as lane intrusion timeouts, climb-over/crawl-under etc.

Emergency and power outage modes

In the event of an emergency, the gate opens the barrier wings (fail-secure mode). During a power outage, however, both the mechanism and barrier wings become unlocked, so they can move freely. Once the emergency alarm stops and/or the electricity returns, the gate resets itself automatically.

LED indicators

The LED lights on the turnstile indicate the operating status in both directions.

Green Passage confirmed
Red No passage

Settings

Operation mode for each directions	Controlled / Free / Locked
Acoustic notifications	On / Off
Release time out	5, 10, 15, 20 sec
Emergency connection	On / Off

SG400 is available in three different cabinet length 1100 mm, 1400 mm, 1750 mm:

- **Center Glass version**
1400 mm, 1750 mm length
- **Boxed version**
1100 mm, 1400 mm, 1750 mm length

Surface treatment

- Anodized
- Stainless Steel
- Powder coating: choose from RAL Classic or Special Powder Coating with premium surface finish.

While both models share the same elegant design language, high-quality build, and advanced functionality, they differ in their configuration.



SG400 Center Glass Stainless



SG400 Boxed Stainless Steel

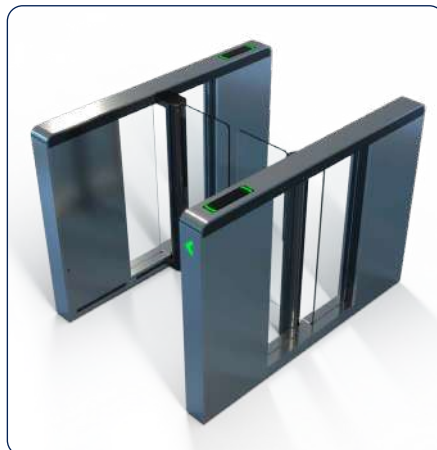

SG400 Center Glass Anodized

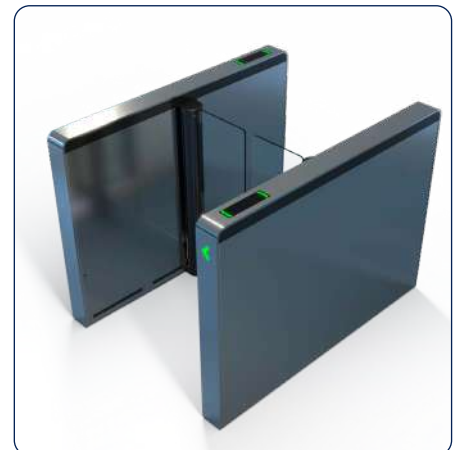

SG400 Boxed Anodized



SG400 Boxed Anodized



SG400 Boxed Anodized

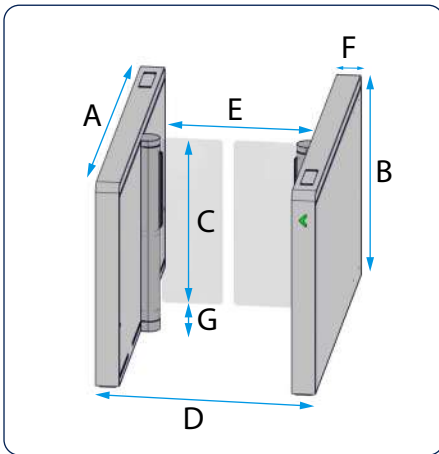

SG400 Boxed / Center Glass – 1750 mm cabinet length

Total Length (A)	1750 mm
Cabinet Height (B)	1019 mm
Barrier Leaf Height (C+G)	970 / 1200 / 1800 mm
Spacing Between Leaves and FFL (G)	135 mm
Total Width (D)	1046 / 1311 / 1596 mm
Clear Passage Width (E)	650 / 915 / 1200 mm
Cabinet Width (F)	112 mm
Spacing Between Leaves	50 mm
Weight	165 kg
Weight Center	195 kg
Sensor	24

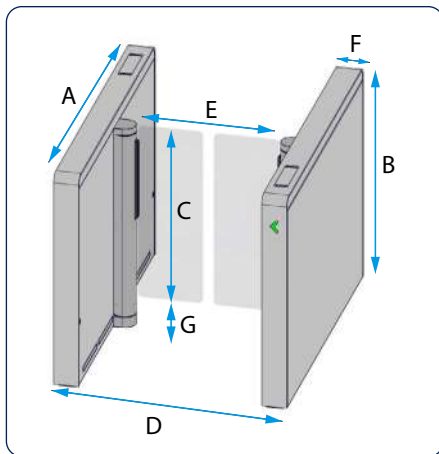

SG400 Boxed / Center Glass – 1400 mm cabinet length

Total Length (A)	1400 mm
Cabinet Height (B)	1019 mm
Barrier Leaf Height (C+G)	970 / 1200 / 1800 mm
Spacing Between Leaves and FFL (G)	135 mm
Total Width (D)	1046 / 1311 / 1396 mm
Clear Passage Width (E)	650 / 915 / 1000 mm
Cabinet Width (F)	112 mm
Spacing Between Leaves	50 mm
Weight	145 kg
Weight Center	175 kg
Sensor	16

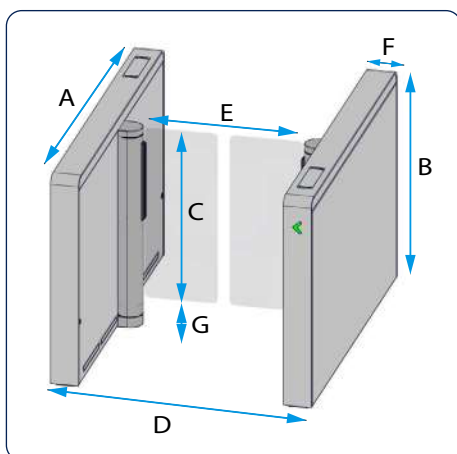

SG400 Boxed – 1100 mm cabinet length

Total Length (A)	1100 mm
Cabinet Height (B)	1019 mm
Barrier Leaf Height (C+G)	970 / 1200 / 1800 mm
Spacing Between Leaves and FFL (G)	135 mm
Total Width (D)	1046 / 1311 mm
Clear Passage Width (E)	650 / 915 mm
Cabinet Width (F)	112 mm
Spacing Between Leaves	50 mm
Weight	130 kg
Weight Center	156 kg
Sensor	10

This equipment should be installed, regularly inspected, maintained and serviced by trained and authorized personnel. Preventive maintenance plans are highly recommended for a proper and safe operation. Talk to your ASSA ABLOY Entrance Systems representative to learn more about our service offering

ASSA ABLOY as word and logo are trademarks owned by the ASSA ABLOY Group.